

Cryogenic Refrigeration Cycle for Re-Liquefaction of LNG Boil-Off Gas

J. W. Moon¹, Y. P. Lee¹, Y. W. Jin², E. S. Hong³,
and H. M. Chang⁴

¹Korea Institute of Science and Technology
Seoul, Korea

²Korea University of Technology and Education
Chungnam, Korea

³Shinyoung Heavy Industries Co.,LTD
Junnam, Korea

⁴Hong Ik University
Seoul, Korea

ABSTRACT

The development of liquefaction process for Liquefied Natural Gas boil-off re-liquefaction plants will be addressed to provide an environmentally friendly and cost effective solution for gas transport. Numerical methods were used for the Claude and the Kaptiza refrigeration cycles. It was found that the Kaptiza refrigeration cycle is more efficient for the Liquid Natural Gas boil-off gas re-liquefaction plant than the Claude cycle in plant operability and cost. The effect of the outlet temperature of the boil-off gas condenser for the nitrogen cycle, and the ratio of expanded mass through turboexpander to the total flow rate mass on the system efficiency of selected LNG boil-off reliquefaction cycle is also delineated here. As a result, the unique optimum value for the ratio of expanded mass through the turboexpander to the total mass flow rate was found to exist.

INTRODUCTION

Recently, there has been a significant increase in the level of interest in environmentally friendly and economically viable solutions for the transport of Liquefied Natural Gas (LNG). LNG carriers have been driven by a steam turbine and the boil-off gas (BOG) from the LNG cargo. The high consumption of the steam turbine as compared to last-generation diesel engines in addition to environmental concerns and future regulation will eventually motivate their replacement. Alternative propulsion systems such as the diesel engine are equipped on the LNG carriers for better fuel economy. Liquefaction of boil-off gases on LNG carriers results in increased cargo deliveries and allows owners and operators to choose the most optimal propulsion system. Instead of the common application of using the boil-off gas as fuel, the LNG BOG reliquefaction system provides a solution to liquefy the boil-off gas back to the cargo tanks. The LNG re-liquefaction system has merit in the large savings in total fuel consumption and improved propulsion redundancy.

The reverse Brayton refrigeration cycle is widely used as the LNG re-liquefaction plant. In case of the reverse Brayton cycle, the turbo-expander is used as the main component to remove

energy from the nitrogen gas stream. To increase efficiency of the re-liquefaction system, a lower expander outlet temperature is required. In this configuration, the liquid droplet may be formed at the expander outlet. The liquid has a much lower compressibility than the gas. When the liquid is formed in the turbo-expander, high momentary stresses would result. However, the Claude system has two expansion units; a turbo-expander and an expansion valve. A higher system efficiency is achieved by using the expander and lower temperature is obtained by using the expansion valve.

In this study, Claude and Kaptiza refrigeration cycles are analyzed for the LNG BOG re-liquefaction system by using a numerical method. The effect of outlet temperature of BOG condenser for the nitrogen cycle, the ratio of expanded mass flow rate through turboexpander to the total mass flow rate on the system efficiency of selected LNG boil-off reliquefaction cycle is also delineated here.

DESIGN SPECIFICATION

The design of the LNG boil-off gas reliquefaction plant has been performed base on the nominal LNG boil-off gas Rate (BOR) of 0.15% of cargo capacity per day for a 220,000 m³ (Full tank filling) LNG carriers. The characteristics of the BOG to be liquefied are as follows.

BOG-composition (mole %):

Methane	92.56%
Nitrogen	7.41%
Ethane	0.03%

Density (mixture): 427.5 kg/m³

Design BOR: 0.15% of cargo volume per day

BOR: 5640 kg/h

BOG pressure: 1.03 bar

This system is basically made of two parts:

- Nitrogen cycle
- LNG BOG cycle

ANALYSIS MODEL

In this study, the basic Claude cycle is shown in Fig. 1. The nitrogen gas is first compressed to high pressure P_H by a 3-stage compressor and then passed through a heat exchanger (HX1). Between 50 and 70 percent of nitrogen gas is then diverted from the mainstream, expanded through a turboexpander, and reunited with the return stream below the second heat exchanger (HX2). The stream to be supplied to the BOG condenser continues through the second (HX2) and third (HX3) heat exchangers and is finally expanded through an expansion valve to the BOG condenser. In the BOG condenser, the cold nitrogen stream undergoes the heat exchange with BOG and liquefies the BOG to liquid LNG. The cold nitrogen vapor from the BOG condenser is returned through the heat exchangers to cool the incoming gas.

To clarify the system design, the inlet and outlet temperature of the 3-stage compressor are set to $T_{c,in}=40$ °C and $T_{c,out}=43$ °C, respectively. The high pressure of the nitrogen cycle is $P_H=58$ bar and the low pressure of the nitrogen cycle is $P_L=14$ bar. The pressure drop through each of the heat exchanger is fixed to 0.1 bar. The adiabatic efficiency of the turboexpander and the compressor of the nitrogen cycle are evenly set to 0.8.

Governing Equations

Steady energy balance equations for the each heat exchanger can be written in terms of specific enthalpy at the each point of the cycle as

$$-h_2+h_9-h_{10}+h_1=0 \quad (1)$$

$$h_8-h_9+(1-x_{exp})(h_2-h_3)=0 \quad (2)$$

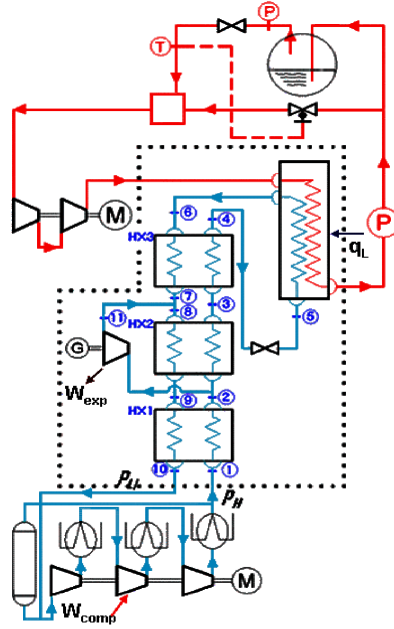

Figure 1. Schematic of Claude cycle refrigerator with turboexpander

$$h_3 - h_4 + h_6 - h_7 = 0 \quad (3)$$

where x_{exp} is the ratio of expanded mass flow rate through the turbo-expander to the total mass flow rate. This can be expressed as

$$x_{exp} = m_{exp} / m_{comp} = m_{11} / m_1 \quad (4)$$

Eq. 5 represents the energy balance for the mixer which mix the fluids from the expander and the heat exchanger.

$$(1 - x_{exp})h_7 + xh_{11} - h_8 = 0 \quad (5)$$

In the JT valve, there is no heat and work transfer. Here the energy balance equation can be written as

$$h_4 = h_5 \quad (6)$$

The effectiveness of the first heat exchanger (HX1) can be written as

$$\begin{aligned} \varepsilon_1 &= \frac{h_{10} - h_9}{h(T_1, P_H) - h_9} && \text{if } h_1 - h(T_9, P_H) \geq h(T_1, P_L) - h_9 \\ &= \frac{h_1 - h_2}{h_1 - h(T_9, P_H)} && \text{otherwise} \end{aligned} \quad (7)$$

The effectiveness of the second heat exchanger (HX2) can be written as

$$\begin{aligned} \varepsilon_2 &= \frac{h_9 - h_8}{h(T_2, P_L) - h_8} && \text{if } (1 - x_{exp})\{h_2 - h(T_8, P_H)\} \geq h(T_2, P_L) - h_8 \\ &= \frac{h_2 - h_3}{h_2 - h(T_1, P_L)} && \text{otherwise} \end{aligned} \quad (8)$$

The effectiveness of the third heat exchanger (HX3) can be written as

$$\begin{aligned} \varepsilon_3 &= \frac{h_7 - h_6}{h(T_3, P_L) - h_6} && \text{if } h_3 - h(T_6, P_H) \geq h(T_3, P_L) - h_6 \\ &= \frac{h_3 - h_4}{h_3 - h(T_6, P_H)} && \text{otherwise} \end{aligned} \quad (9)$$

Adiabatic efficiency can be written as

$$\eta_{\text{exp}} = \frac{h_2 - h_{11}}{h_2 - h_{11s}}, \quad \text{where } h_{11} = h(P_H, s_{11}) \text{ and } h_{11s} = h(P_L, s_2) \quad (10)$$

Coefficient of Performance (COP) can be written as

$$\text{COP} = \frac{q_L}{W_{\text{comp}} - W_{\text{exp}}} \quad (11)$$

BASIC DESIGN

At first, the basic design of LNG BOG re-liquefaction plant is performed using the Claude system. To clarify the system design, the inlet and outlet temperature of the 3-stage compressor are set to $T_{c,\text{in}} = 40^\circ\text{C}$ and $T_{c,\text{out}} = 43^\circ\text{C}$, respectively. The high pressure of the nitrogen cycle is $P_H = 58$ bar and the low pressure of the nitrogen cycle is $P_L = 14$ bar. The effectiveness of each heat exchanger is set to 0.95. The pressure drop through each the heat exchanger is fixed to 0.1 bar. The adiabatic efficiency of the turbo expander and the compressor of the nitrogen cycle are set to 0.7. The outlet temperature of the BOG condenser is assumed to be -140°C . The basic design result using the Claude cycle is shown in Table 1. The results show that the temperature difference between the inlet and the outlet of third heat exchanger (HX3) is less than 1°C . Therefore, the basic Claude system is modified by eliminating the third heat exchanger with the intent of reducing the initial cost, as shown in Fig. 2. This modified Claude system is the Kapitsa system. For realistic system designs, the pressure drop through the heat exchanger is changed from 0.1 bar to 0.25 bar. The inlet temperature and pressure of the BOG condenser at the BOG side are set to -49.63°C and 3.25 bar, respectively. The outlet temperature and pressure of BOG condenser at the BOG side are -161°C and 3.0 bar, respectively. For the optimal design of LNG boil-off gas re-liquefaction plant, the affect of the various input parameters, such as the effectiveness of the heat exchangers, outlet temperature of BOG condenser for the nitrogen cycle, and the ratio of the expanded mass flow rate through the turbo-expander to the total mass flow rate, on the system efficiency of selected LNG boil-off re-liquefaction cycle are presented here.

RESULTS AND DISCUSSION

The effect of heat exchanger effectiveness on the coefficient of performance (COP) is exemplified in Fig. 3. The heat exchanger effectiveness is varied from 0.85 to 0.95 when the outlet temperature of the BOG condenser held at $T_5 = -150^\circ\text{C}$. As the heat exchanger effectiveness increases, the COP increases while the optimum values for the ratio of expanded mass flow rate through the turbo expander to the total mass flow rate decreases is shown in Fig. 3. The results also show that

Table 1. Basic design results of LNG BOG re-liquefaction plant

Location	Pressure P.(bar)	Temperature T(C)	Location	Pressure P.(bar)	Temperature T(C)
1	58.0	43.0	8	14.5	-139.0
2	57.9	-83.5	9	14.4	-100.7
3	57.8	-137.6	10	14.3	35.6
4	57.7	-138.1	11	14.5	-139.7
5	14.6	-163.2 $x=0.55$	BOG _{in}	3.3	-49.6
6	14.5	-140	BOG _{out}	3.0	-161
7	14.5	-137.8			

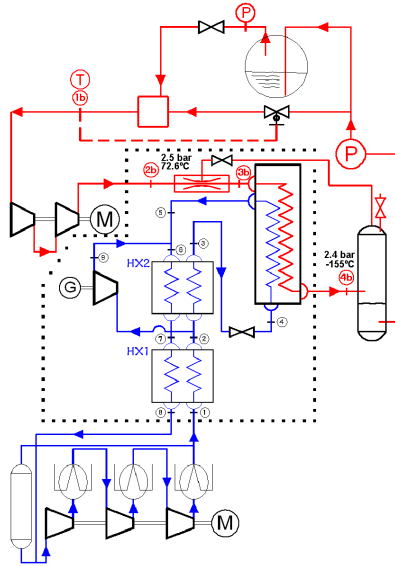

Figure 2. Schematic of Kaptiva cycle refrigerator with turboexpander

the effectiveness of the first heat exchanger (HX1) has a more dominant effect on the COP than the second heat exchanger (HX2). In the second heat exchanger, the mass flow rate of the high pressure side is about two times than that of the low pressure side. This may be attributed to the high heat capacity of the low pressure stream. In this region, the effect of heat capacity to the heat transfer is too dominant for temperature difference to affect the heat exchange ratio from one stream to another stream. Therefore, the effectiveness of each heat exchanger is set to 0.95 for HX1 and 0.9 for HX2, respectively.

The effect of the outlet temperature of the BOG condenser for the nitrogen cycle, T_5 is shown in Fig. 4. The outlet temperature of the BOG condenser is varied from -150°C to -120°C . As the outlet temperature of the BOG condenser for the nitrogen cycle, T_5 , increases, the COP is little affected by the increase of T_5 . While the optimum values for the ratio of expanded mass flow rate through the turboexpander to the total mass flow increases as shown in Fig. 4. As T_5 decreases, the range of x_{exp} also narrowed. This means that the system cannot deal with a wide range of load variation when the outlet temperature of the BOG condenser is too high. For the stability of the LNG BOG re-liquefaction system, the outlet temperature of the BOG condenser at the nitrogen stream is set to $T_5 = -150^\circ\text{C}$.

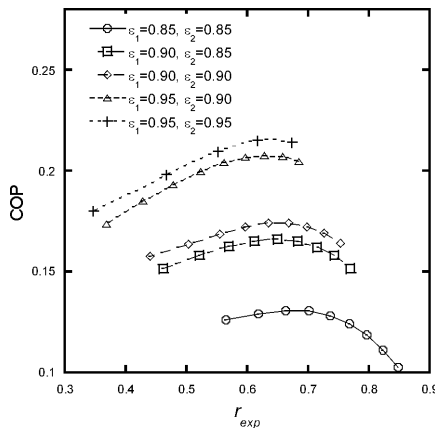

Figure 3. The effect of heat exchanger effectiveness on COP.

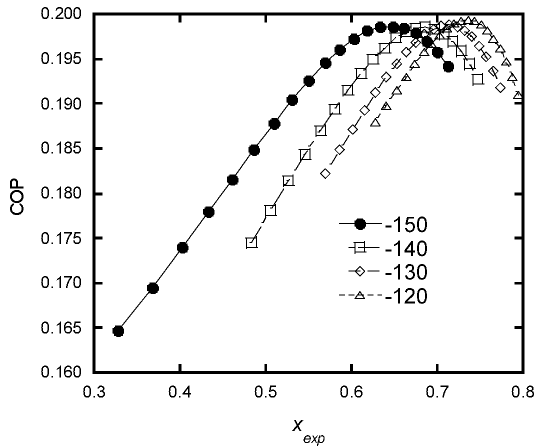

Figure 4. COP as a funtion of expanded mass ratio and outlet temperature of BOG condenser $\epsilon_1=0.95$, $\epsilon_2=0.9$ and $\eta_{exp}=0.7$.

Table 2. Basic design results of LNG BOG re-liquefaction plant usingthe Kaptiva system

Location	Pressure P·(bar)	Temperature T(C)	Location	Pressure P·(bar)	Temperature T(C)
1	59.30	43.00	8	14.00	40.6
2	59.05	-79.51	9	1450	-138.2
3	58.80	-137.9	BOG _{in}	3.25	-49.6
4	14.75	-163 x=0.55	BOG _{out}	3.00	-161
5	14.50	-140	W _{comp}	6002·kW	
6	14.50	-138.8	W _{exp}	976.6·kW	
7	14.25	-98.3	Q _{cond}	966·kW	

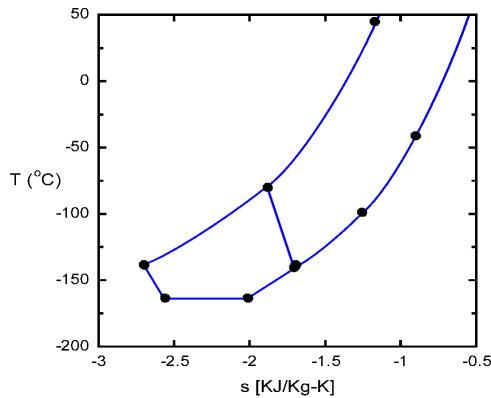

Figure 5. LNG boil-off re-liquefaction system on T-s diagram of nitrogen at the optimal operation.

Based upon the results of the parametric study, the following system condition is selected for the LNG BOG re-liquefaction system. The details of the system are shown in Table 2 and the T-s diagram is displayed in Fig. 5.

CONCLUSION

In this study, numerical methods are used to analyze the Claude and the Kaptiza refrigeration cycles. It was found that Kaptiza refrigeration cycle is more efficient in plant operability and cost for the LNG BOG re-liquefaction plant than the Claude cycle. The effect of outlet temperature of BOG condenser for the nitrogen cycle, the ratio of expanded mass flow rate through turbo-expander to the total mass flow rate on the system efficiency of selected LNG boil-off re-liquefaction cycle is also delineated here. The results indicate that there exist unique optimum values for the ratio of expanded mass flow rate through the turboexpander to the total mass flow rate.

REFERENCES

1. Baek, J.H. and Chang, H.M., "Cycle Analysis of 2-Stage Expansion Claude Refrigerator with Turboexpanders," *Journal of Sarek*, vol. 6, no. 2 (1994), pp. 130-139.
2. Barron, R.F., *Cryogenic System*, Second Edition, Oxford University Press, New York (1985), pp. 357-362.
3. Haywood, R.W., *Analysis of Engineering Cycles*, Third Edition, Pergamon Press, New York (1990),